

High Pressure Triplex Plunger Pump PC Series Catalogue

Model Selection Chart

Model	SPM	Flow Rate in LPM (GPM)	Max. Rated Pressure in Bar (PSI)				
			15 HP	20 HP	25 HP	30 HP	40 HP
PC-12	420	5 (1.32)	1000 (14503)	1200 (17404)	-	-	-
PC-12	540	7 (1.84)	800 (11603)	1000 (14503)	1200 (17404)	-	-
PC-12	730	9 (2.37)	600 (8702)	800 (11603)	1000 (14503)	1200 (17404)	-
PC-14	730	13 (3.43)	-	-	600 (8702)	800 (11603)	1000 (14503)
PC-16	730	17 (4.49)	-	-	-	600 (8702)	750 (10877)

Note: All flow is based on 100% volumetric efficiency. Actual flow will be $\geq 85\%$.

Dimension

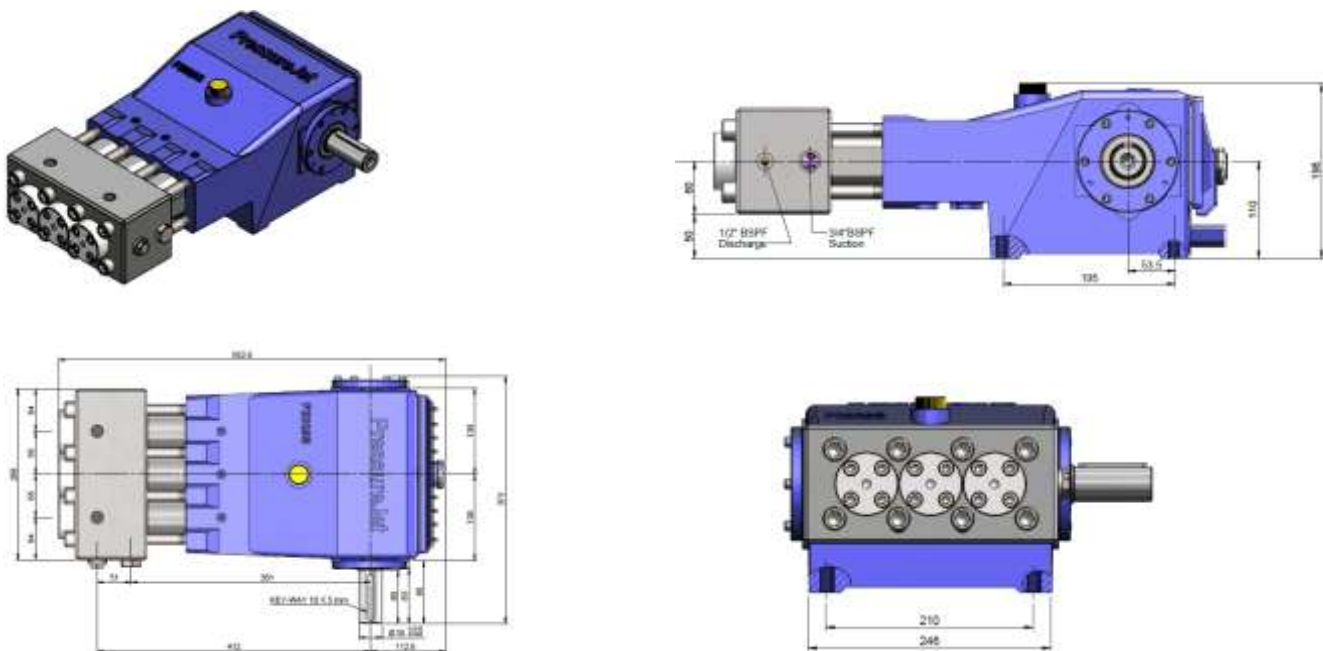

Note: All dimensions are in mm & weight of bare pump is 85 Kg approx.

Salient Features

- Field proven design. Easy field maintenance.
- Rigorously subjected to full load testing.
- Manufactured on state-of-the-art machinery.
- Heavy duty construction, light in weight.
- PC series triplex plunger pumps available in three versions.
- Splash lubrication.
- Available with Gear drive arrangement.

Technical Specifications

- Stroke length: 40 mm
- Max. plunger speed: 1.26 m/sec. @ 950 SPM
- Plunger force: 12.45 KN (1271 kgf)
- Inlet pressure min.-max.: 2-3 Bar (Booster pump flow require minimum 1.5 times of rating flow)
- Oil type: Gear oil 220
- Oil capacity: 4 Ltrs.
- Max. permissible oil temp.: Room temp.+ 50°C
- Max. inlet water temp.: 5°C to 60°C
- Inlet connection: 3/4 " BSPF
- Outlet connection: 1/2 " BSPF

Types of Systems

- Skid mounted system with electric motor and diesel engine
- Trolley mounted system with electric motor and diesel engine
- Road going trailer with electric motor and diesel engine
- All unit available in four side cover or canopy on request

Material of Construction

• **Power End**

1. **Main body (Crank case)**

Main body in grey iron casting FG-260. With Honed surface finish bore.

2. **Crankshaft**

Spheroidal graphite iron crankshaft is made of nitrated, hardened and tempered spheroidal graphite iron casting.

3. **Connecting rod**

Alloy steel forged steel connecting rods with antifriction bearings. Heavy pin area construction, for added load strength.

4. **Piston (Cross head)**

Alloy Steel alloy steel construction for hard surface coating and super finish.

5. **Bearing**

Oversized for maximum life and load disbursement. Self-alignment roller bearing enables it to handle 26% more load than other pumps.

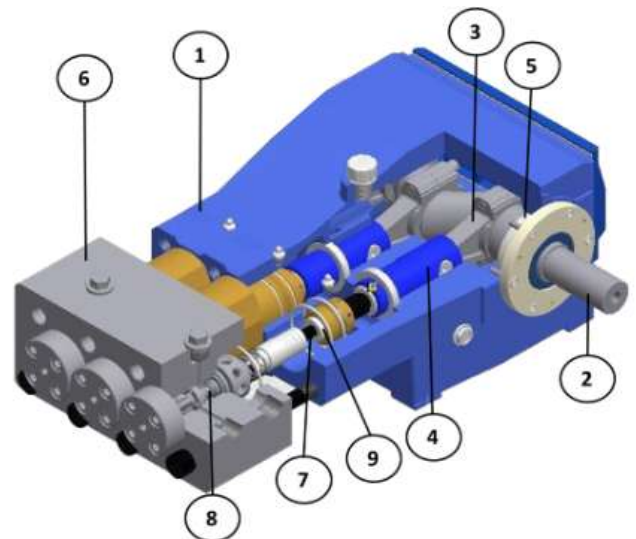

• **Fluid End**

6. **Pump Head**

Stainless Steel liquid end is made of high corrosion resistant forged SS410.

7. **Plunger**

Primarily composed of **Tungsten coated**. Surface roughness is extremely good i.e. **<0.2 Ra**.

8. Complete Valve

Stainless steel valves made stainless steel for hardened & anti corrosion hard surface coated for long life. High volumetric efficiency valves operate at 95% efficiency plus.

9. Plunger Seal

PTFE Aramide rope "V" style strong and tightens under load or Aramide fibre yarn packing for high compressive & tensile strength ensure effective sealing.

Contact us

PressureJet Systems Pvt. Ltd.

21-24 Panchratna Industrial Estate

Village : Paldi Kankaj, Taluka : Dascroi

Ahmedabad – 382427, Gujarat, India

Mobile: +91 93750 22359

E-mail: sales@pressurejet.com

Website: www.pressurejet.com